

## CP-USC-VA13FR3

1.3MP Cosmic HD Array Vandal Dome Camera - 30Mtr.

**COSMIC**  
HD CAMERA

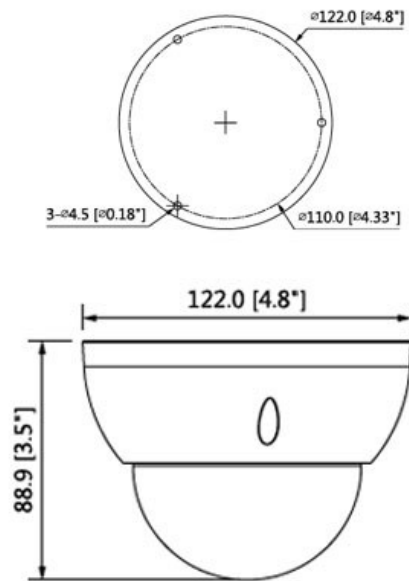

### Main Features

- 1/3" 1.3MP CMOS Image Sensor
- Max 30fps@1.3MP
- DWDR, Day/Night (ICR), 2D-DNR, AWB, AGC, BLC
- 2.7-13.5mm Vari-focal lens
- Array Range of 30 Mtrs, IP67, IK10
- OSD Menu, control over coaxial cable, 2D-DNR
- HD and SD output switchable



\*Product casing and specifications are subject to change without prior notice

# CP- USC-VA13FR3

1.3MP Cosmic HD Array Vandal Dome Camera - 30Mtr.

**COSMIC**  
HD CAMERA

## Feature

Image Sensor  
Minimum Illumination  
Shutter Speed  
White Balance  
Gain Control (AGC)  
Lens  
Back Light Compensation  
S/N Ratio  
Video Streaming  
Video Output  
ICR  
OSD  
IR  
Operating Temperature  
Power Source  
Power Consumption  
Weatherproof Standard  
Dimension  
Weight

## Specification

1/3" 1.3 MP PS CMOS Image Sensor  
0.05Lux/F1.3, 0 Lux IR on, 30IRE  
PAL: 1/25~1/100000s , NTSC: 1/30~1/100000s  
Auto/Manual  
Auto/Manual  
2.7-13.5mm vari-focal lens  
BLC/ HLC/ DWDR  
More than 65dB  
25/30fps@1.3MP  
1-channel BNC high definition video output/ CVBS standard definition video output (Can switch)  
Auto (ICR) / Manual  
Supports  
Array Range of 30 Mtr.  
-40°C~+60°C (-40°F ~ +140°F) , Less than 90%RH  
DC12V±25%  
Max 2.9W (12V DC, IR on)  
IP67, IK10  
Φ122mm x 88.9mm  
0.40kg